

TB 9-6625-1314-35

CHANGE 1

DEPARTMENT OF THE ARMY TECHNICAL BULLETIN

CALIBRATION PROCEDURE FOR DIGITAL VOLTMETER, HEWLETT-PACKARD, MODEL 3439A OR C28-3439A WITH C15-3444A AND 3444A PLUG-INS; DIGITAL VOLTMETER, HEWLETT-PACKARD, MODEL 3440A WITH 3445A OR C06-3445A PLUG-INS AND HIGH GAIN AUTO RANGE UNIT MODEL 3443A; AND DIGITAL MULTIMETER, DATA TECHNOLOGY, MODEL 360

Headquarters, Department of the Army, Washington, DC
31 August 1981

TB 9-6625-1314-35, 30 August 1979, is changed as follows:

1. Remove old pages and insert new pages as indicated below. New or changed material is indicated by a vertical bar in the margin of the page.

Remove pages

3 and 4
9 and 10
17 and 18
23 through 26

Insert pages

3 and 4
9 and 10
17 and 18
23 through 26

2. File this change sheet in front of the publication for reference purposes.

By Order of the Secretary of the Army:

E. C. MEYER
General, United States Army
Chief of Staff

Official:

ROBERT M. JOYCE
Brigadier General, United States Army
The Adjutant General

Distribution:

To be distributed in accordance with DA Form 12-34C, Block No. 319, requirements for calibration procedures publications.

PIN: 043301-001

REPRINT INCLUDES CHANGE 1

***TB 9-6625-1314-35**

DEPARTMENT OF THE ARMY TECHNICAL BULLETIN

**CALIBRATION PROCEDURE FOR
DIGITAL VOLTMETER
HEWLETT-PACKARD MODEL 3439A OR C28-3439A
WITH C15-3444A AND 3444A PLUG-INS;
DIGITAL VOLTMETER,
HEWLETT-PACKARD MODEL 3440A
WITH 3445A OR C06-3445A PLUG-IN AND
HIGH GAIN AUTO RANGE UNIT MODEL 3443A; AND
DIGITAL MULTIMETER,
DATA TECHNOLOGY MODEL 360**

Headquarters, Department of the Army, Washington, DC
30 August 1979

REPORTING OF ERRORS

You can help improve this publication by calling attention to errors and by recommending improvements and stating your reasons for the recommendations. Your letter or DA Form 2028, Recommended Changes to Publications, should be mailed directly to Commander, U.S. Army Aviation and Missile Command, ATTN: AMSAM-TMD-EP, Redstone Arsenal, AL 35898-5000. FAX to DSN 788-2313 (commercial 256-842-2313). A reply will be furnished directly to you.

		Paragraph	Page
SECTION	I. IDENTIFICATION AND DESCRIPTION		
	Test instrument identification.....	1	3
	Calibration data card, DA form 2416.....	2	3
	Calibration description	3	3
	II. EQUIPMENT REQUIREMENTS		
	Equipment required.....	4	5
	Accessories required	5	5
	III. CALIBRATION PROCESS FOR DIGITAL VOLTMETER, HEWLETT-PACKARD MODELS 3439A OR C23-3439A WITH C15-3444A OR 3444A PLUG-INS		
	Preliminary instructions.....	6	8

*This bulletin supersedes TB 9-6625-1314-35, 27 October 1971, including all changes.

	Paragraph	Page
Equipment Setup	7	9
Dc volts and stability	8	9
Resistance	9	13
Dc current (Level A)	10	14
Dc current (AN/GSM-256, AN/GSM-259, and AN/TSM-55)	11	16
Power supply	12	18
Final procedure.....	13	18
IV. CALIBRATION PROCESS FOR DIGITAL VOLTMETER, HEWLETT-PACKARD MODEL 3440A WITH AC/DC RANGE UNIT 3445A OR C06-3445A		
Preliminary instructions	14	19
Equipment setup.....	15	19
Dc volts and stability (Level A and AN/GSM-259)....	16	20
Ac volts (Level A and AN/GSM-259)	17	22
Power supply	18	24
Final procedure.....	19	24
V. CALIBRATION PROCESS FOR HIGH GAIN AUTO RANGE UNIT, MODEL 3443A		
Preliminary instructions	20	24
Equipment setup.....	21	25
Dc volts	22	26
Final procedure.....	23	27
VI. CALIBRATION PROCESS FOR DIGITAL MULTIMETER, DATA TECHNOLOGY MODEL 360		
Preliminary instructions	24	28
Equipment setup.....	25	28
Dc volts and stability	26	29
Dc current (Level A)	27	30
Dc current (AN/GSM-256, AN/GSM-259, and AN/TSM-55)	28	32
Ac volts (Level A and AN/GSM-259)	29	33
Ac volts (AN/GSM-256 and AN/TSM-55).....	30	34
Ac current (Level A)	31	36
Ac current (AN/GSM-256)	32	38
Ac current (AN/GSM-259 and AN/TSM-55)	33	39
Resistance	34	40
Final procedure.....	35	41

**SECTION I
IDENTIFICATION AND DESCRIPTION**

1. Test Instrument Identification. This bulletin provides instructions for the calibration of Digital Voltmeter Hewlett-Packard Model 3439A or C28-3439A with C15-3444A and 3444A plug-ins; Digital Voltmeter, Hewlett-Packard Model 3440A with 3445A or C06-3445A Plug-in and High Gain Auto Range Unit Model 3443A; and Digital Multimeter, Data Technology Model 360. The manufacturer's instruction manuals were used as the prime data source in compiling these instructions. The equipment being calibrated will be referred to as the TI (test instrument) throughout this bulletin.

a. Model Variations. Model variations which affect calibration are described in text.

b. Time and Technique. The time required for this calibration is approximately 4 hours per instrument, using the dc (direct current) and low frequency technique.

2. Calibration Data Card, DA Form 2416

a. Forms, records, and reports required for calibration personnel at all levels are prescribed by TM 38-750. DA Form 2416 must be annotated in accordance with TM 38-750 for each calibration performed.

b. Adjustments to be reported on DA Form 2416 are designated (R) at the end of the sentence in which they appear. When adjustments are in tables, the (R) follows the designated adjustment. Report only those adjustments made and designated with (R).

3. Calibration Description. TI parameters and performance specifications which pertain to this calibration are listed in tables 1 through 3.

Table 1. Calibration Description for Digital Voltmeter, Hewlett-Packard Model 3439A or C28-3439A with 3444A or C15-3444A Plug-ins

Test instrument parameters	Performance specifications
Dc volts Range Accuracy	100 mV to 1000 V in five ranges ±0.1% of reading ±1 digit from 99.99 to 999.9 mV ±0.05% of reading ±1 digit from 9.999 V to 999.9 V
Dc current Range ¹ Accuracy	99.99 µA to 999.9 mA in five ranges ±0.2% of reading ± 1 digit
Resistance Range Accuracy	0 Ω to 9.999 MΩ in five ranges ±0.3% of reading ±1 digit, except ±1% ±1 digit on 10 MΩ range

¹1000 mA range not calibrated at Level C.

TB 9-6625-1314-35

Table 2. Calibration Description for Digital Voltmeter, Hewlett-Packard, Model 3440A with 3445A or C06-3445A and 3443A plug-ins

Test instrument parameters	Performance specifications
Dc volts (model 3440A with 3445A or C06-3445A plug-in installed) ¹ Range Accuracy	0 to 999.9 V in three ranges ±0.05% of reading ± 1 digit
Dc volts (model 3443A) ¹ Range Accuracy Range Accuracy	99.99 mV to 999.9 mV ±0.1% of reading ± 1 digit 9.999 V to 999.9 V ±0.05% of reading ± 1 digit
Ac volts (for 3445A) ¹ Range Accuracy	0 to 999.19 V in three ranges ±0.1% of reading ±2 counts (50 Hz to 20 kHz) ±0.1% FS ±2 counts (20 to 50 kHz) ±0.3% FS ±2 counts (50 to 100 kHz) (linearly derated from ±0.1% FS ±2 counts at 50 kHz to ±0.3% FS ±2 counts at 100 kHz)
Ac volts (for C06-3445A) ¹ Range Accuracy	0 to 999.9 V in three ranges ±0.1% of reading ±2 counts (50 Hz to 10 kHz) ±0.2% FS ±2 counts (10 to 30 kHz) ±0.3% FS ±2 counts (30 to 100 kHz)

¹Not calibrated at AN/GSM-256 and AN/TSM-55.

Table 3. Calibration Description for Digital Multimeter, Data Technology Model 360

Test instrument parameters	Performance specifications
Dc volts Range Accuracy Range Accuracy	200 mV and 100 V ±(0.1% of reading +0.2 FS) 2, 20, and 200 V ±(0.1% of reading +0.1 FS)
Dc current Range Accuracy Range Accuracy	0.2, 2, 20, and 200 mA ±(0.2% of reading + 0.2 FS) 2A ±(0.5% of reading +0.3 FS)
Ac volts ¹ Range Accuracy Range Accuracy Range Accuracy	0.2 to 750 V (50 Hz to 10 kHz) ±(0.7% of reading +0.3 FS) 0.2 and 2 V (10 to 20 kHz) ±(2% of reading +0.4% FS) 0.2 and 2 V (20 to 100 kHz) ±(5% of reading +0.6% FS)

See footnote at end of table.

Table 3. Calibration Description for Digital Multimeter,
Data Technology, Model 360 - Continued

Test instrument parameters	Performance specifications
Ac current ^{2 3} Range Accuracy	0.2 mA to 2 A (50 Hz to 10 kHz) (±.7% of reading +0.3% FS)
Resistance Range Accuracy Range Accuracy	0.2 to 200 k Ω ±(0.3% of reading +0.2% FS) 2000 k Ω ±(0.5% of reading +0.2% FS)

¹ 200 and 2000 V range calibrated at 60 and 400 Hz (AN/GSM-256 and AN/TSM-55).

² Calibrated 50 Hz to 1 kHz on 0.2 to 200 mA range, and 60 and 400 Hz on 2000 mA range (AN/GSM-256).

³ Calibrated 60 and 400 Hz (AN/GSM-259 and AN/TSM-55). 1200 and 2000 V range calibrated at 60 and 400 Hz (AN/GSM-256 and AN/TSM-55).

SECTION II EQUIPMENT REQUIREMENTS

4. Equipment Required. Table 4 identifies the specific equipment used in this calibration procedure. This equipment is issued with Secondary Transfer Calibration Standards Sets NSN 6695-00-621-7877, NSN 6695-00-525-8175 (AN/GSM-256), NSN 49-01-019-1829 (AN/GSM-259), and Transportable Maintenance Calibration Facility AN/TSM-55, and is to be used in performing this procedure. Alternate items may be used by the calibrating activity when the equipment listed in table 4 is not available. The items selected must be verified to perform satisfactorily prior to use and must bear evidence of current calibration. The equipment must meet or exceed the minimum use specifications listed in table 4. The accuracies listed in table 4 provide a four-to-one accuracy ratio between the standard and TI.

5. Accessories Required. The accessories listed in table 5 are issued as indicated in paragraph 4 above and are to be used in this calibration procedure. When necessary, these items may be substituted by equivalent items unless specifically prohibited.

TB 9-6625-1314-35

Table 4. Minimum Specifications of Equipment Required

Item	Common name	Minimum use specifications	Manufacturer and model (part number)			
			Level A	AN/GSM-256	AN/GSM-259	AN/TSM-55
A1	AC AMMETER CALIBRATOR (CALIBRATION AMPLIFIER)	Range: 199.9 μ A to 2 A at 50 Hz to 1 kHz Accuracy: ± 1	Holt, Model 250 (7912648)	Not required	Not required	Not required
A2	AC VOLTAGE CALIBRATOR (PRECISION STANDARD AC CALIBRATION)	Range: 0 to 1000 V ac Accuracy: $\pm 0.025\%$ (50 Hz to 50 kHz)	Hewlett-Packard, Model 745/C90 MIS-10342 Type 1 with C/90746 (C90746)	John Fluke, Model 760 (760A)	Same as Level A	Same as AN/GSM-256
A3	AC/DC VOLTMETER	Range: 99.78 mV to 35 V Accuracy: ^{1 2}	Dana, Model 5000S2351 (5000S2351)	Hewlett-Packard, Model 3490A (3490A OPTION 060)	Same as AN/GSM-256	John Fluke, Model 883AB (TS-283414)
A4	AC POWER SUPPLY	Range: 50 Hz to 10 kHz, 0.2 mA to 2 A ac	N.H. Research, Model SF613 (MIS-10222)	Elgar, Model 121 (121)	Not required	Not required
A5	AUTOTRANSFORMER (VARIABLE POWER TRANSFORMER)	Range: 105 to 125 V ac Accuracy: $\pm 1\%$	General Radio, Model W10M T3AS3 (7910809)	Same as Level A	Same as Level A	General Radio, Model W10M T3A
A6	DC CURRENT SHUNT	Range: 199.9 μ A to 2 A Accuracy: ²	Guildline, Model 9711 (7912323)	Not required	Not required	Not required
A7	DC VOLTAGE STANDARD	Range: 99.8 mV to 1000 V dc Accuracy: $\pm 0.0125\%$	John Fluke, Model 332/A (332B/AF)	John Fluke 760 (760A)	Same as Level A	Same as AN/GSM-256
A8	DECADE RESISTANCE STANDARD (RESISTANCE STANDARD)	Range: 10.0 Ω to 2 M Ω Accuracy: ³	Biddle-Gray Model 60114-84 (7910309) and model CR10M	Biddle-Gray, Model 71-631 General Radio, Model 1433Y	Same as AN/GSM-256	General Radio, Model 1433Y and Model 1434N
A9	DECADE RESISTOR	Range: 0 to 2 A	Winslow, Model 336 (7907234)	Same as Level A	Same as Level A	Clarostat, Model 240C (ZM/58U)
A10	DC POWER SUPPLY	Range: 199.9 A to 2A	NJE, Model CS36CR30 (7907346-2)	Not required	Not required	Not required

Table 4. Minimum Specifications of Equipment Required - Continued

Item	Common name	Minimum use specifications	Manufacturer and model (part number)			
			Level A	AN/GSM-256	AN/GSM-259	AN/TSM-55
A11	ELECTRICAL TEST SET	Range: 97 mV to 1000 ac and dc Accuracy: $\pm(33\%)$ Current range: 100 μ A to 1 A Accuracy: ± 0.25 range $\pm 0.25 \mu$ A	Not required	John Fluke, Model 760 (760A)	Same as AN/GSM-356	Same as AN/GSM-256
A12	SIGNAL SOURCE (AF RF OSCILLATOR)	Range: 0 to 3 V rms Accuracy: 100 Hz to 20 kHz $\pm 2\%$	Not required	Hewlett-Packard Model 652A (MIS-10224)	Not required	Same as AN/GSM-256
A13	TEST OSCILLATOR	Range: 0 to 20 V rms Accuracy: 0 to 10 kHz $\pm 2\%$	Not required	Not required	Not required	General Radio, Model GR1310B (AN/USM-269)
A14	VOLTMETER	Must be compatible with TI and calibrated	Hewlett-Packard, Model 3439A or 3440A	Same as Level A	Same as Level A	Same as Level A

¹Combined accuracy of (A1) and (a3) $\pm 0.25\%$.

²Combined accuracy of (A3) and (A6) $\pm 0.05\%$.

³Ohms: $\pm 0.125\%$

Dc: Combined accuracy of A8 and A3 $\pm 0.05\%$.

Ac: Combined accuracy of A8 and A3 $\pm 0.25\%$.

Table 5. Accessories Required

Item	Common name (official nomenclature)	Description (part number)
B1	ADAPTER ¹	Banana jack to spade lug (red) (790750-2)
B2	CABLE ASSEMBLY	30-in., RG-58/U with double banana terminations (7907470)
B3	LEAD	4-in., No. 18 with single banana plug terminations (7907491)
B4	LEAD ²	24-in., No. 18 with single banana plug terminations (7907497)
B5	LEAD ³	High current cable with spade plug terminations (7911541-2)
B6	TEST LEAD	36-in., RG-58/U double banana plug to BNC terminations (7907471)

¹Two required.

²Five required.

³Four required.

SECTION III
CALIBRATION PROCESS FOR DIGITAL VOLTMETER, HEWLETT-PACKARD
MODEL 3439 OR C28-3439A WITH C15-3444A OR 3444A PLUG-INS

6. Preliminary Instructions

a. **6** **7**
process. Personnel should become familiar with the applicable sections before beginning

b Items of equipment used in this procedure are referenced within the text by common equipment referenced by item numbers prefixed with A, see table 4, and for prefix B, see

WARNING

calibration. DEATH ON CONTACT may result if personnel

NOTE

whenever the test requirement is not met, take corrective
required to calibrate the TI are included in this procedure.
manufacturer's manual for this TI.

NOTE

When indications specified in paragraphs **8** through **11** are not within tolerance, perform the power supply check prior to making adjustments. After adjustments are made, repeat paragraphs **8** through **11**. Do not perform power supply check if all other parameters are within tolerance.

NOTE

Unless otherwise specified, all controls and control settings refer to the TI.

7. Equipment Setup

- a.** Remove TI protective cover as required for adjustments.
- b.** Install plug-in(model C15-3444A or 3444A) into TI main frame (model 3439A or C28-3439A).
- c.** If necessary, set 115-220 power switch, located on rear panel, to 115.
- d.** Connect TI to autotransformer (A5).
- e.** Connect autotransformer to 115 V ac (volt alternating current) source and adjust for 115 V.
- f.** Set TI LINE switch to on (up) position and allow at least 30 minutes for warm-up.

8. Dc Volts and Stability

a. Performance Check

- (1) Set FUNCTION switch to VOLTS and RANGE switch to 10 V.
- (2) Short INPUT terminals (⁺ to red) using lead (B3).
- (3) adjust rear panel ZERO adjust to obtain an indication of 0.000 on TI. If 0.000 cannot be obtained, perform **b**(1) through (6) below.

NOTE

Optimum adjustment is obtained when the + (plus) and - (minus) indicators light alternately.

- (4) Press INT CHECK 8000 pushbutton and adjust the INT CHECK 8000 adjustment to obtain an indication of -8.000 on TI. Release INT CHECK 8000 pushbutton.
- (5) Set RANGE switch to 100 mV and adjust front panel ZERO, adjust to obtain an indication of 00.00 on TI.

TB 9-6625-1314-35

(6) Remove short connected in (2) above.

(7) Connect dc voltage standard (A7) for Level A and AN/GSM-259 calibration or electrical test set (A11) and ac/dc voltmeter (A3) for AN/GSM-256 and AN/TSM-55 calibration to TI INPUT terminals using leads (B4).

(8) Adjust output of dc voltage standard or electrical test set to obtain an indication of 99.99 on TI. If dc voltage standard or ac/dc voltmeter does not indicate between 99.880 and 100.10 mV, perform **b**(7) through (35) below.

(9) Adjust autotransformer between 105 and 125 V while repeating technique of (8) above. Dc voltage standard on ac/dc voltmeter indication will remain between 99.880 and 100.10 mV.

(10) Adjust autotransformer to 115 V.

(11) Repeat technique of (8) above using RANGE switch settings and indications listed in table 6. If dc voltage standard or ac/dc voltmeter does not indicate within limits specified, perform **b**(7) through (35) below.

Table 6. Dc Volts

Test instrument		Dc voltage standard or ac/dc voltmeter indication (V dc)	
RANGE switch	Indication	Min	Max
1000 MV	999.9	0.99880	1.0010
10 V	9.999	9.9930	10.0050
10 V	9.000	8.9945	9.0055
10 V	8.000	7.9950	8.0050
10 V	7.000	6.9955	7.9945
10 V	6.000	5.9960	6.0040
10 V	5.000	4.9965	5.0035
10 V	4.000	3.9970	4.0030
10 V	3.000	2.9975	3.0025
10 V	2.000	1.9980	2.0020
10 V	1.000	0.9985	1.0015
100 V	99.99	99.930	100.050
1000 V	999.9	999.30	1000.50

b. Adjustments

(1) Position rear panel ZERO adjust to its mechanical midposition.

(2) Adjust A2R70 COMPARATOR BALANCE ADJ (fig. 1) to obtain an indication of 0.000 on TI (R).

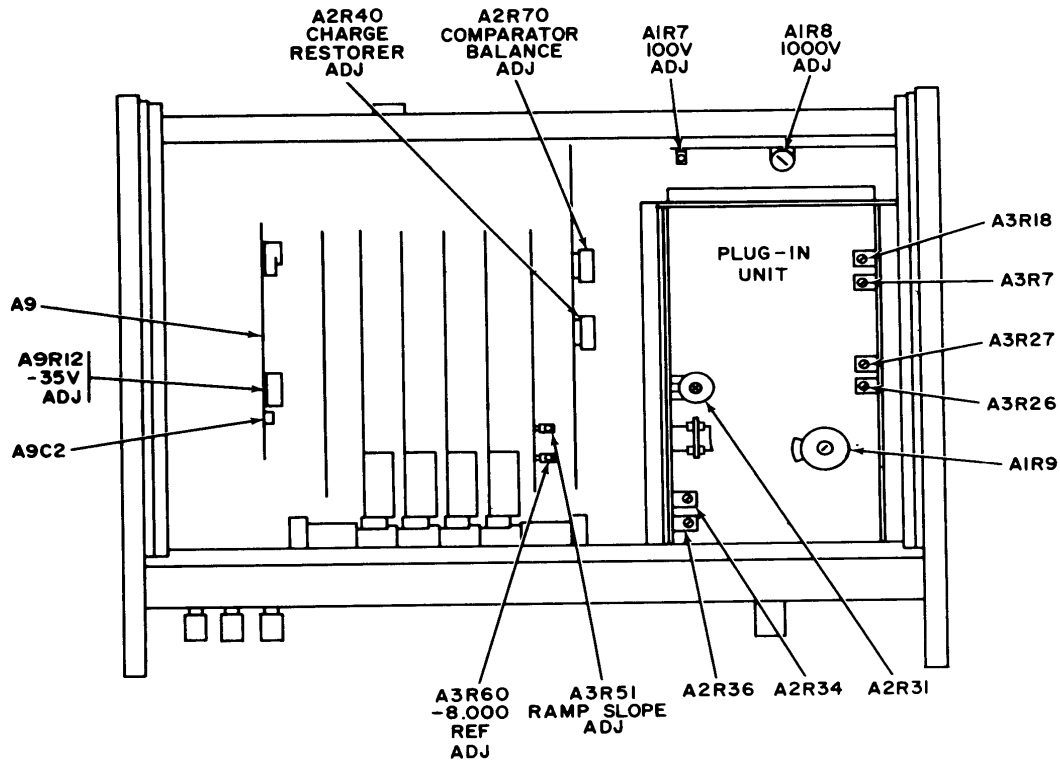

Figure 1. Digital voltmeter - top view.

Adjust rear panel ZERO adjustment to obtain an indication of 0.000 with + (plus) and -

- (4) Remove short from INPUT terminals.

Adjust A2R40 CHARGE RESTORER ADJ (fig. 1) to obtain an indication of 0.000 with + (plus) and - (minus) indicator lights flashing alternately (R).

Repeat a(2) and (3) above.

Set RANGE switch to 10 V

- (8)

(9) Position INT CHECK 8000 adjustment to its (approximately five turns from fully cw (clockwise) position).

(10)) to obtain an indication of +8.000 on TI (R). If required, fine adjust, using INT CHECK 8000 adjustment (R).

TB 9-6625-1314-35

- (11) Set RANGE switch to 100 V.
- (12) Adjust dc voltage standard or electrical test set for an output of 80.00 V.
- (13) Adjust A1R7 100 V ADJ (fig. 1) to obtain an indication of +80.00 on TI (R).
- (14) Set RANGE switch to 1000 V.
- (15) Adjust dc voltage standard or electrical test set for an output of 800.00 V.
- (16) Adjust A1R8 1000 V ADJ (fig. 1) to obtain an indication of +800.0 on TI (R).
- (17) Reduce output of dc voltage standard or electrical test set and reverse lead connections.
- (18) Adjust dc voltage standard or electrical test set for an output of 8.000 V.
- (19) Set RANGE switch to 10 V
- (20) Adjust INT CHECK 8000 adjustment to obtain an indication of -8.000 on TI (R).
- (21) Press INT CHECK 8000 pushbutton and adjust A3 R60 -8.000 REF ADJ (fig. 1) to obtain an indication of -8.000 on TI (R). Release pushbutton.
- (22) Adjust dc voltage standard or electrical test set output to zero. Short TI INPUT terminals, using lead (B3).
- (23) Set RANGE switch to 100 MV and adjust front panel ZERO adjust to obtain an indication of 00.00 on TI (R).
- (24) Set RANGE switch to 1000 MV and adjust A2R31 (fig. 1) to obtain an indication of 0000 (R).
- (25) Remove short installed in (22) above and connect dc voltage standard or electrical test set for positive output.
- (26) Adjust dc voltage standard or electrical test set for an output of 800.0 mV.
- (27) Adjust A2R36 (fig. 1) to obtain an indication of 800.0 (R).
- (28) Connect dc voltage standard or electrical test set for negative output and repeat (26) above.
- (29) If required, readjust A2R36 and repeat (25) through (28) above until TI indicates between 799.9 and 800.1 for both positive and negative outputs of dc voltage standard or electrical test set.
- (30) Connect dc voltage standard or electrical test set for positive output.

Table 7. Resistance

Test instrument		Decade resistance standard indication (ohms) ¹	
RANGE switch	Indication	Min	Max
1000 (ohms)	500.0	498.40	501.60
1000 (ohms)	999.9	996.80	1003.0
10K (ohms)	9.999	9.9680 k	10.030 k
100 K (ohms)	99.99	99.680 k	100.30 k
1000 K (ohms)	999.9	996.80 k	10030 k
10 M (ohms)	9.000	8.9090 M	9.0910 M

¹Use additional resistance standard as required.

b. Adjustments

- (1) Set RANGE switch to 10 K (ohms).
- (2) Set decade resistance standard to 10,000 ohms.
- (3) Adjust A3R18 (fig. 1) to obtain an average indication of 0.000 (R).

NOTE

This is an indication of 10,000 ohms.

- (4) Set RANGE switch to 10 M (ohms).
- (5) Set decade resistance standard to 9 megohms.
- (6) Adjust A3R7 (fig. 1) to obtain an indication of 9.000 on TI (R).
- (7) Repeat **a**(3) through (6) above.

10. Dc Current (Level A)

a. Performance Check

- (1) Set FUNCTION switch to VOLTS and RANGE switch to 100 MV. If necessary, adjust front panel ZERO adjust to obtain an indication of 00.00 on TI.
- (2) Connect equipment as shown in figure 2.
- (3) Set FUNCTION switch to AMPS and RANGE switch to 100 μ A.
- (4) Insert dc current shunt (A6) range plugs in the .0001 AMPERES position.
- (5) Adjust dc voltage standard (A7) output and decade resistor (A9) to obtain an indication of 99.99 on TI. If ac/dc voltmeter (A3) does not indicate between 99.780 and 100.21 mV, perform **b** below.

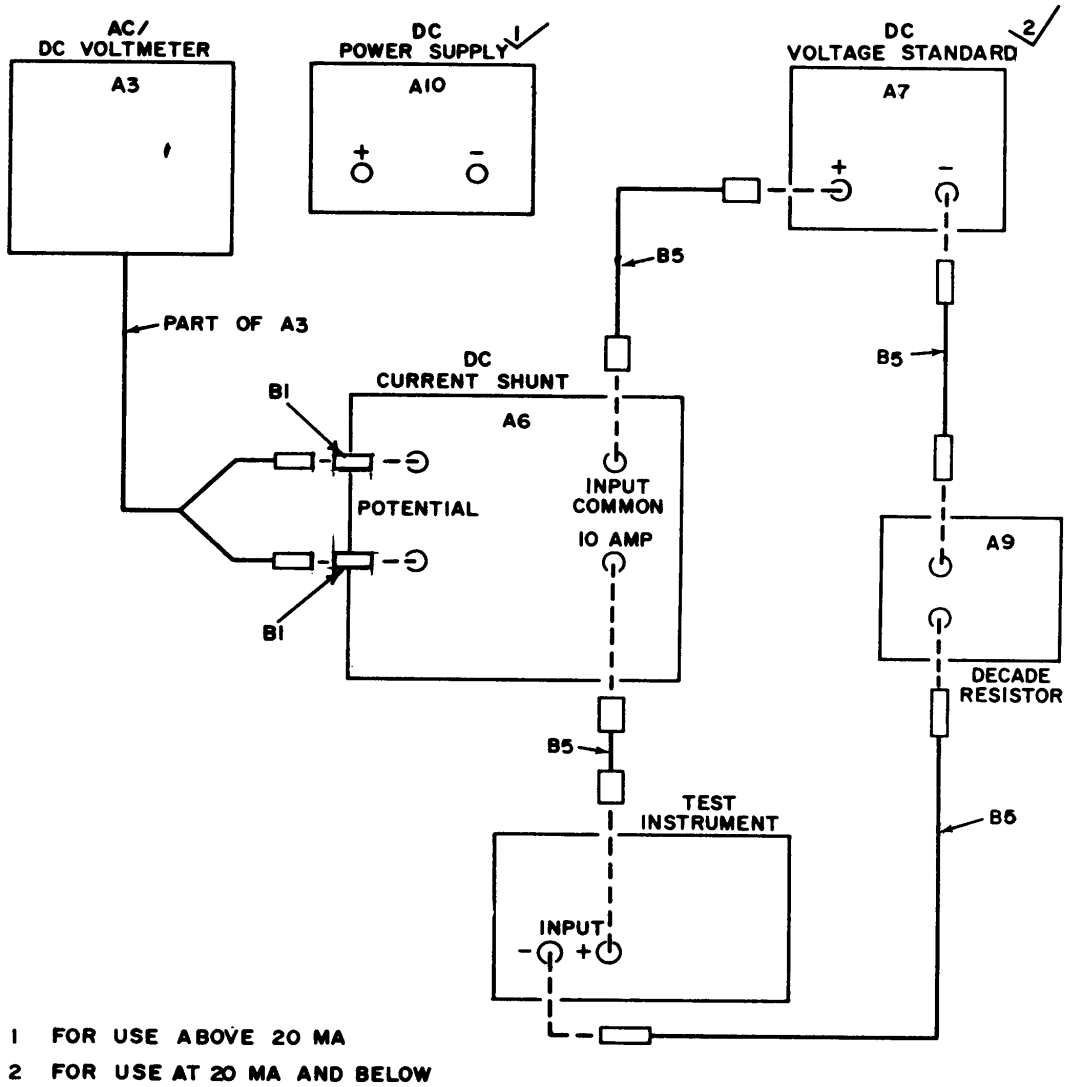

Figure 2. Dc current - equipment setup.

(6) Repeat technique of (3) through (5) above using values fisted in table 8. If ac/dc voltmeter does not indicate within limits specified, perform **b** below.

Table 8. Dc Current (Level A)

Current shunt range plugs AMPERES position	Test Instrument		Ac/dc voltmeter indication (mV)	
	RANGE Switch setting	Indication	Min	Max
.001	1000 μ A	999.9	99.78	100.21
.01	10 MA	9.999	99.78	100.21
.1	100 MA	99.99	99.78	100.21
1	1000 MA	999.9	99.78	100.21

TB 9-6625-1314-35

b. Adjustments

- (1) Set RANGE switch to 100 MA.
- (2) Insert dc current shunt range plugs in .1 AMPERES position.
- (3) Adjust dc power supply and decade resistor to obtain an indication of 100 mV on ac/dc voltmeter.
- (4) Adjust A3R26 (fig. 1) to obtain an average indication of 00.00 on TI (R).
- (5) Set RANGE switch to 1000 MA.
- (6) Insert dc current shunt range plugs in 1 AMPERES position.
- (7) Repeat (3) above.
- (8) Adjust A3R27 (fig. 1) to obtain an overrange indication of 000.0 on TI (R).
- (9) Repeat **a**(1) through (6) above.

11. Dc Current (AN/GSM-256, AN/GSM-259, and AN/TSM-55)

a. Performance check

- (1) Set FUNCTION switch to VOLTS and RANGE switch to 100 MV. If necessary, adjust front panel ZERO adjust to obtain an indication of 00.00 on TI.
- (2) Connect equipment as shown in figure 3, connection A.

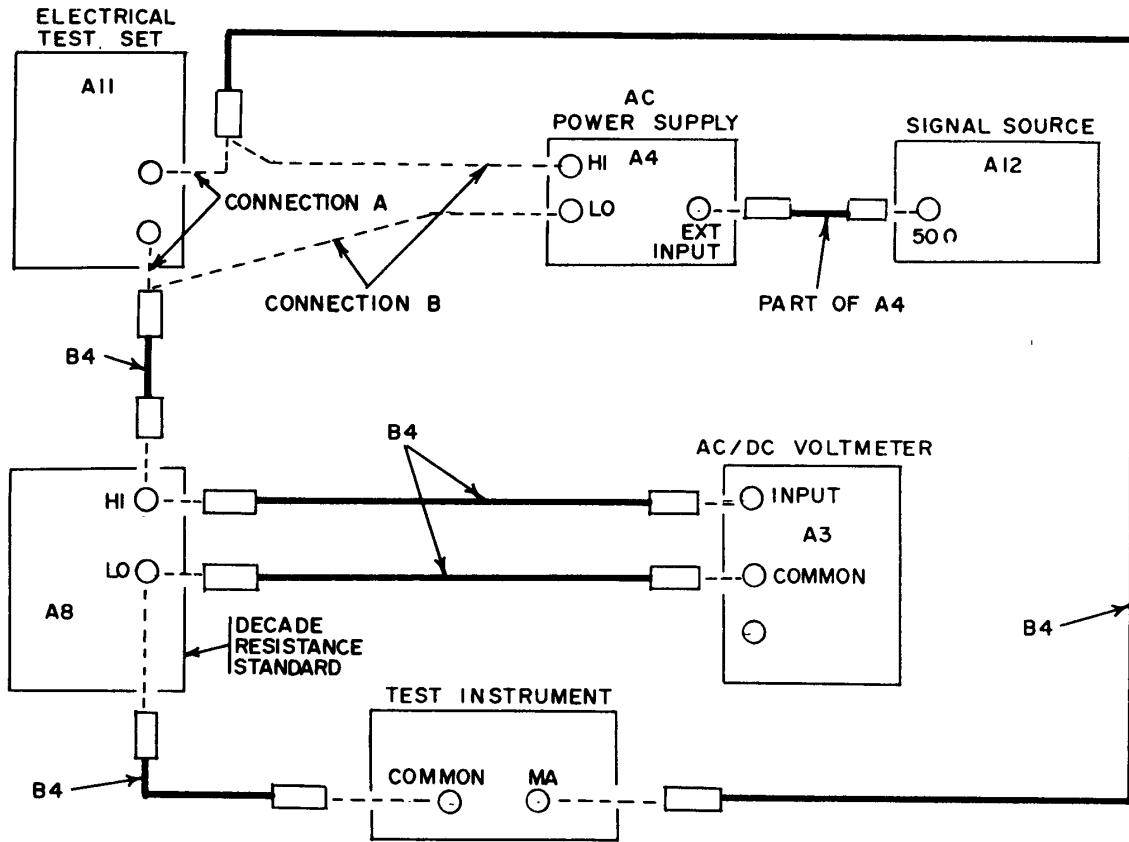

Figure 3. Dc and ac current (AN/GSM-256, AN/GSM-259 and AN/TSM-55) - equipment setup.

(3) Set FUNCTION switch to AMPS and RANGE switch to 100 μ A.

CAUTION

All decade positions of decade resistance standard (A8) must be set exactly as specified in (4) below and table 9 to assure maximum current limits of the decades are not exceeded.

Table 9. Dc Current (AN/GSM-256, AN/GSM-259, and AN/TSM-55)

Decade resistance standard setting	Test instrument		Ac/dc voltmeter indications (V dc)	
	RANGE switch	Indication	Min	Max
001000.00	1000 μ A	999.9	0.9969	1.0029
000100.00	10 MA	9.999	0.9969	1.0029
000010.00	100 MA	99.99	0.9969	1.0029

TB 9-6625-1314-35

(4) Set decade resistance standard (A8) to 010001.00.

(5) Adjust electrical test set (A11) to obtain an indication of 99.99 μ A on TI. If ac/dc voltmeter does not indicate between 0.9969 and 1.0029 V, perform **b** below.

(6) Repeat technique of (3) through (5) above, using settings listed in table 9. If ac/dc voltmeter does not indicate within limits specified, perform **b** below.

b. Adjustments

(1) Set RANGE switch to 100 MA.

(2) Set decade resistance standard to indicate 10 ohms.

(3) Adjust power supply to obtain an indication of 1.0000 mV on ac/dc voltmeter.

(4) Adjust A3R26 (fig. 1) until TI indicates an average of 00.00 (R).

12. Power Supply

a. Performance Check

NOTE

Do not perform power supply check if all other parameters are within tolerance.

(1) Connect ac/dc voltmeter (A3) between terminal 15 of A9 (negative end of A9C2, fig. 1) and chassis ground.

(2) If ac/dc voltmeter does not indicate between -34.65 and -35.35 V dc, perform **b** below.

b. Adjustments. Adjust A9R12 -35 V ADJ (fig. 1) to obtain an indication of -35 V dc on ac/dc voltmeter (R).

13. Final Procedure. In accordance with TM 38-750, annotate and affix DA Label 80 (US Army Calibrated Instrument). When the TI receives limited or special calibration, annotate and affix DA Label 163 (US Army Limited or Special Calibration). When the TI cannot be adjusted within tolerance, annotate and affix DA Form 2417 (US Army Calibration System Rejected Instrument).

SECTION IV
CALIBRATION PROCESS FOR DIGITAL VOLTMETER, HEWLETT-PACKARD
MODEL 3440A WITH AC/DC RANGE UNIT 3445A OR C06-3445A

14. Preliminary Instructions

a. The instructions outlined in paragraphs **14** and **15** are preparatory to the calibration process. Personnel should become familiar with the applicable sections before beginning the calibration.

b. Items of equipment used in this procedure are referenced within the text by common name and item identification number as listed in tables 4 and 5. For the identification of equipment referenced by item numbers prefixed with A, see table 4, and for prefix B, see table 5.

WARNING

HIGH VOLTAGE is used during the performance of this calibration. DEATH ON CONTACT may result if personnel fail to observe safety precautions.

NOTE

Unless otherwise specified, verify the results of each test and, whenever the test requirement is not met, take corrective action before continuing with the calibration. Adjustments required to calibrate the TI are included in this procedure. Additional maintenance information is contained in the manufacturer's manual for this TI.

NOTE

When indications specified in paragraphs **16** and **17** are not within tolerance, perform the power supply check prior to making adjustments. After adjustments are made, repeat paragraphs **16** and **17**. Do not perform power supply check if all other parameters are within tolerance.

NOTE

Unless otherwise specified, all controls and control settings refer to the TI.

15. Equipment Setup

- a.** Remove TI protective cover as required for adjustments.
- b.** Install TI plug-in (model 3445A or C06-3445A) into TI main frame (model 3440A).
- c.** If necessary, set 115-220 power switch, located on rear panel, to 115.

TB 9-6625-1314-35

- d. Connect TI to autotransformer (A5).
- e. Connect autotransformer to 115 V ac source and adjust for 115 V.
- f. Set TI SAMPLE RATE control fully ccw (counterclockwise) (but not to LINE OFF), and allow at least 30 minutes for warm-up.

16. Dc Volts and Stability (Level A and GSM-259)

a. Performance Check

- (1) Set FUNCTION switch to DC and RANGE switch to 10 V.
- (2) Short TI plug-in INPUT terminals, using lead (B3).
- (3) Adjust TI rear panel ZERO adjustment to obtain an indication of 0.000 on TI. If 0.000 cannot be obtained, perform **b**(1) through (7) below.

NOTE

Optimum adjustment is indicated by alternate flashing of the + (plus) and - (minus) lights.

- (4) Remove short from INPUT terminals.
- (5) Depress and hold INT CHECK 8000 pushbutton and adjust INT CHECK 8000 adjustment to obtain an indication of -8.000. Release INT CHECK 8000 pushbutton.
- (6) Connect dc voltage standard (A7) to TI plug-in INPUT, using two leads (B4).
- (7) Adjust output of dc voltage standard to obtain an indication of 9.000 on TI. If dc voltage standard does not indicate between 8.9945 and 9.0055 V, perform **b**(8) through (21) below.
- (8) Adjust autotransformer (A5) between 105 and 125 V while repeating (7) above.
- (9) Adjust autotransformer to 115 V.
- (10) Repeat technique of (7) above, using RANGE switch settings and indications listed in table 10. If dc voltage standard does not indicate within limits specified, set RANGE switch to 10 V and perform **b**(8) through (21) below.

Table 10. Dc Volts

Test instrument		Dc voltage standard indications (V dc)	
RANGE switch setting	Indication	Min	Max
10 V	9.999	9.9930	10.0050
10 V	8.000	7.9950	8.0050
10 V	7.000	6.9955	7.0045
10 V	6.000	5.9960	6.0040
10 V	5.000	4.9965	5.0035
10 V	4.000	3.9970	4.0030
10 V	3.000	2.9975	3.0025
10 V	2.000	1.9980	2.0020
10 V	1.000	0.9985	1.0015
100 V	99.99	99.930	100.050
1000 V	999.9	999.30	1000.50

b. Adjustments

- (1) Set rear panel ZERO adjustment to its mechanical midposition.
- (2) Adjust A2R70 COMPARATOR BALANCE ADJ (fig. 1) to obtain an indication of 0.000 on TI (R).
- (3) Adjust rear panel ZERO adjustment to obtain an indication of 0.000 on TI with + (plus) and - (minus) indication lights flashing alternately.
- (4) Remove short from INPUT terminals.
- (5) Adjust A2R40 CHARGE RESTORER ADJ (fig. 1) to obtain an indication of 0.000 on TI with + (plus) and - (minus) indicator lights flashing alternately (R).
- (6) Set SAMPLE RATE control for a TI indication of approximately one sample per second. If TI indication does not remain at 0.000 repeat **a**(2) and **b**(1) through (5) above.
- (7) Repeat **a**(2) and (3) above.
- (8) Set INT CHECK 8000 adjustment to its mechanical midrange.
- (9) Adjust dc voltage standard for an output of 8.000 V.
- (10) Adjust A3R51 RAMP SLOPE ADJ (fig. 1) to obtain an indication of 8.000 on TI. Adjust INT CHECK 8000 for fine adjustment if required (R).
- (11) Set RANGE switch to 100 V.
- (12) Adjust dc voltage standard for an output of 80.000 V.
- (13) Adjust A1R7 100 V ADJ (fig. 1) to obtain an indication of 80.00 on TI (R).

TB 9-6625-1314-35

- (14) Set RANGE switch to 1000 V.
- (15) Adjust dc voltage standard for an output of 800.00 V.
- (16) Adjust A1R8 1000 V ADJ (fig. 1) to obtain an indication of 800.00 on TI (R).
- (17) Adjust dc voltage standard for a negative output of - 8.000 V.
- (18) Set RANGE switch to 10 V.
- (19) Adjust INT CHECK 8000 adjustment to obtain an indication of -8.000 on TI (R).
- (20) Press and hold INT CHECK 8000 pushbutton.
- (21) Adjust A3R60 -8.000 REF ADJ (fig. 1) to obtain an indication of -8.000 on TI (R). Release INT CHECK 8000 pushbutton.

17. Ac Volts (Level A and AN/GSM-259)**a. Performance Check**

- (1) Connect ac voltage calibrator (A2) to TI plug-in INPUT, using cable (B2).
- (2) Set TI FUNCTION switch to AC and RANGE switch to 10 V
- (3) Adjust ac voltage calibrator frequency to 1 kHz and voltage to obtain an indication of 9.000 TI. If ac voltage calibrator does not indicate between 8.9890 and 9.0110, perform **b**(1) and (2) below.
- (4) Repeat technique of (3) above at frequencies and settings listed in table 11. If ac voltage calibrator does not indicate within limits specified, perform appropriate adjustments listed in the table 11.

b. Adjustments

- (1) Adjust ac calibrator for an output of 9.0000 V.
- (2) Adjust A4R30 (fig. 4) to obtain an indication of 9.000 on TI.

Table 11. Ac Volts

Test instrument		Ac voltage calibrator			Adjustments	
RANGE switch setting	Indication	Frequency	Indications		Optimum value (V).	Adjustments (fig. 4).
			Min	Max		
10 V	8.000	1000 Hz	7.9900	8.0100	---	---
10 V	6.000	1000 Hz	5.9920	6.0080	---	---
10 V	4.000	1000 Hz	3.9940	4.0060	---	---
10 V	2.000	1000 Hz	1.9960	2.0040	---	---
10 V	9.000	50 Hz	8.9890	9.0110	---	---
10 V	9.000	20 kHz	8.9890 ¹	9.0110 ¹	9.0000	A1C1 (R)
10 V	9.000	50 kHz	8.9880	9.0120	---	---
10 V	9.000	100 kHz	8.9680	9.0320	9.000	A1L2 (R)
100 V	90.00	1000 Hz	89.890	90.110	90.000	A2R2 (R)
100 V	90.00	50 Hz	89.890	90.110	---	---
100 V	90.00	20 kHz	89.890 ²	90.110 ²	90.000	A2C7 (R)
100 V	90.00	50 kHz	89.880	90.120	---	---
100 V	90.00	100 kHz	89.680	90.320	---	---
1000 V	900.0	1000 Hz	898.90	901.10	900.00	A2R4 (R)
1000 V	900.0	50 Hz	898.90	901.10	---	---
1000 V	900.0	20 kHz	898.90 ³	901.10 ³	900.00	A2C4 (R)
1000 V	900.0	50 kHz	898.80	901.20	---	---
1000 V	900.0	100 kHz	896.80	903.20	---	---

¹C06-3455A limits are 8.9780 to 9.0220.

²C06-3455A limits are 89.780 to 90.220.

³C06-3455A limits are 897.80 to 902.20.

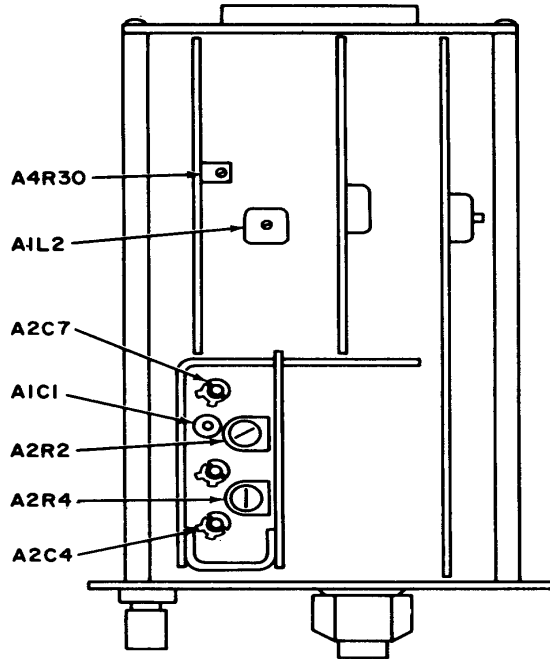

Figure 4. Ac/dc range unit - adjustment locations.

18. Power Supply

a. Performance Check

NOTE

Do not perform power supply check if all other parameters are within tolerance.

(1) Set SAMPLE RATE control to HOLD.

(2) Connect ac/dc voltmeter (A3) between terminal 15 of A9 (negative end of A9C2, fig. 1) and chassis ground. If ac/dc voltmeter does not indicate between -34.65 and -35.35 V dc, perform **b** below.

b. Adjustments. Adjust A9R12 -35 V ADJ (fig. 1) to obtain an indication of -35.00 V on ac/dc voltmeter.

19. Final Procedure. In accordance with TM 38-750, annotate and affix DA Label 80 (US Army Calibrated Instrument). When the TI receives limited or special calibration, annotate and affix DA Label 163 (US Army Limited or Special Calibration). When the TI cannot be adjusted within tolerance, annotate and affix DA Form 2417 (US Army Calibration System Rejected Instrument).

SECTION V

CALIBRATION PROCESS FOR HIGH GAIN AUTO RANGE UNIT, MODEL3443A

20. Preliminary Instructions

a. The instructions outlined in paragraphs **20** and **21** are preparatory to the calibration process. Personnel should become familiar with the applicable sections before beginning the calibration.

b. Items of equipment used in this procedure are referenced within the text by common name and item identification number as listed in tables 4 and 5. For the identification of equipment referenced by item numbers prefixed with A, see table 4, and for prefix B, see table 5.

WARNING

HIGH VOLTAGE is used during the performance of this calibration. DEATH ON CONTACT may result if personnel fail to observe safety precautions.

NOTE

Unless otherwise specified, verify the results of each test and, whenever the test requirement is not met, take corrective action before continuing with the calibration. Adjustments required to calibrate the TI are included in this procedure. Additional maintenance information is contained in the manufacturer's manual for this TI.

NOTE

Unless otherwise specified, all controls and control settings refer to the TI.

21. Equipment Setup

- a. Insert TI into voltmeter (A14).
- b. Connect voltmeter to 115 V ac source.
- c. Energize voltmeter and allow at least 30 minutes for warm-up.
- d. Short voltmeter INPUT, using lead (B3).
- e. Set RANGE switch to 10 V.
- f. Adjust voltmeter rear panel ZERO adjustment to obtain an indication of 0.000 on voltmeter with + (plus) and - (minus) lights flashing alternately.
- g. Remove short from INPUT terminals.
- h. Press and hold voltmeter INT CHECK 8000 pushbutton and adjust INT CHECK 8000 adjustment to obtain an indication of -8.000 on voltmeter. Release pushbutton.
- i. Set TI RANGE switch to 100 MV.
- j. Repeat **d** above.
- k. Adjust TI ZERO adjust to obtain an indication of 00.00 on voltmeter with + (plus) and - (minus) lights flashing alternately.
- l. Set TI RANGE switch to 1000 MV.
- m. If required, adjust A2R33 (fig. 5) to obtain an indication of 000.0 on voltmeter.

NOTE

TI must be removed for adjustment. Adjust in increments until desired indication is obtained.

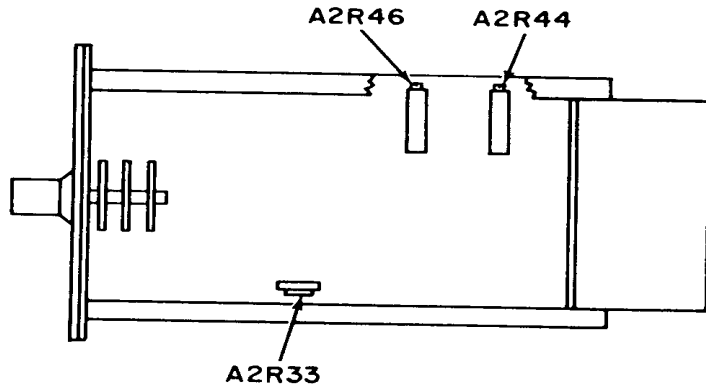

Figure 5. High gain auto range unit - top view.

22. Dc Volts

a. Performance Check

(1) Connect dc voltage standard (A7) for Level A and AN/GSM-259 calibration, or electrical test set (A11) and ac/dc voltmeter (A3) for AN/GSM-256 and AN/TSM-55 calibration, to voltmeter (A14) INPUT terminals using two leads (B4).

(2) Set RANGE switch to 100 MV.

(3) Adjust output of dc voltage standard or electrical test set to obtain an indication of 90.00 on voltmeter (A14). If dc voltage standard or ac/dc voltmeter does not indicate between 89.900 and 90.100 mV, perform **b** below.

(4) Repeat technique of (2) and (3) above using settings and indications listed in table 12. If dc voltage standard or ac/dc voltmeter does not indicate within limits specified, and no adjustment was required in (3) above, perform **b** below.

Table 12 Range and Accuracy

Test instrument		Dc voltage standard or ac/dc voltmeter indications (V dc)	
RANGE switch setting	Indication	Min	Max
1000 MV	900.0	0.89900	0.90100
1000 MV	700.0	0.69920	0.70080
1000 MV	500.0	0.49940	0.50060
1000 MV	300.0	0.29960	0.30040
1000 MV	100.0	0.09980	0.10020
10 V	9.000	8.9945	9.0055
100 V	90.00	89.945	90.055
1000 V	900.0	899.45	905.55

b. Adjustments

- (1) Press and hold INT CHECK 8000 pushbutton and adjust INT CHECK 8000 adjustment to obtain an indication of 8000 on voltmeter (A14). Release pushbutton.
- (2) Set RANGE switch to 1000 MV.
- (3) Adjust dc voltage standard or electrical test set for an output of +800.0 mV.
- (4) Adjust A2R46 (fig. 5) until voltmeter (A14) indicates +800.0 (R).

NOTE

TI must be removed from voltmeter to perform adjustment.
Adjust in increments until desired indication is obtained.

- (5) Reverse dc voltage standard or electrical test set output polarity.
- (6) If voltmeter (A14) does not indicate between -799.1 and -800.9, readjust A2R46 to compensate for error between positive and negative indications.
- (7) Adjust dc voltage standard or electrical test set output to zero.
- (8) Set RANGE switch to 100 MV.
- (9) Short voltmeter (A14) INPUT, using lead (B3).
- (10) If voltmeter (A14) does not indicate 000.0 readjust A2R33 (fig. 5) until voltmeter indicates 000.0.
- (11) Remove short placed in (9) above.
- (12) Adjust dc voltage standard or electrical test set for an output of -80.00 mV.
- (13) Adjust A2R44 (fig. 5) until voltmeter (A14) indicates -80.00 (R).
- (14) Reverse dc voltage standard or electrical test set output polarity
- (15) Repeat **a**(1) through (4) above.

23. Final Procedure. In accordance with TM-38-750, annotate and affix DA Label 80 (US Army Calibrated Instrument). When the TI receives limited or special calibration, annotate and affix DA Label 163 (US Army limited or Special Calibration). When the TI cannot be adjusted within tolerance, annotate and affix DA Form 2417 (US Army Calibration System Rejected Instrument).

**SECTION VI
CALIBRATION PROCESS FOR DIGITAL MULTIMETER,
DATA TECHNOLOGY MODEL 360**

24. Preliminary Instructions

a. The instructions outlined in paragraphs **24** and **25** are preparatory to the calibration process. Personnel should become familiar with the entire bulletin before beginning the calibration.

b. Items of equipment used in this procedure are referenced within the text by common name and item identification number as listed in tables 4 and 5. For the identification of equipment referenced by item numbers prefixed with A, see table 4, and for prefix B, see table 5.

WARNING

HIGH VOLTAGE is used during the performance of this calibration. DEATH ON CONTACT may result if personnel fail to observe safety precautions.

NOTE

Unless otherwise specified, verify the results of each test and, whenever the test requirement is not met, take corrective action before continuing with the calibration. Adjustments required to calibrate the TI are included in this procedure. Additional maintenance information is contained in the manufacturer's manual for this TI.

NOTE

Unless otherwise specified, all controls and control settings refer to the TI.

25. Equipment Setup

- a.** Connect TI to autotransformer (A5).
- b.** Connect autotransformer to 115 V ac source and adjust for 115 V.
- c.** Set TI POWER switch to ON and allow at least 30 minutes for warm-up.
- d.** Press DC function and .2 range switch.
- e.** Connect lead (B3) between TI VOLTS and COM terminals.
- f.** If necessary adjust ZERO control (fig 6) to obtain an indication of 000.0 on TI.

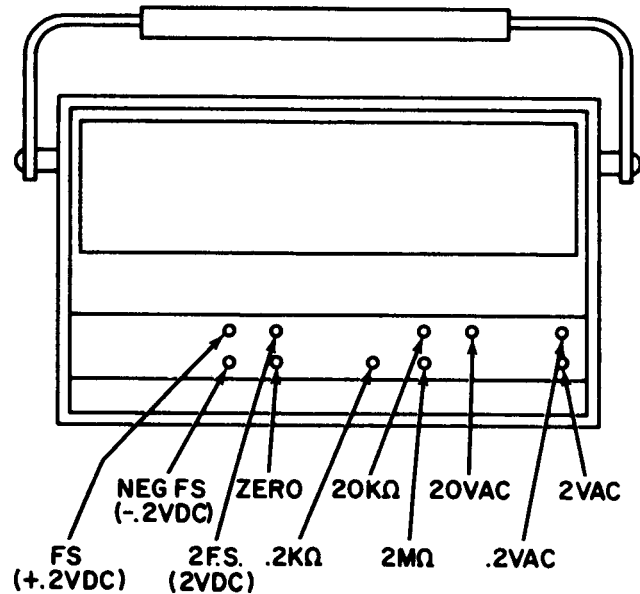

**NOTE: ADJUSTMENTS LOCATED BEHIND
NAMEPLATE**

Figure 6. Digital multimeter - adjustment locations.

- g.** Remove lead from VOLTS and COM terminals.

26. Dc Volts and Stability

a. Performance check

(1) Connect dc voltage standard (A7) for Level A and AN/GSM-259 calibration or electrical test set (A11) and ac/dc voltmeter (A3) for AN/GSM-256 and AN/TSM-55 calibration to TI using leads (B4).

(2) Adjust output of dc voltage standard or electrical test set to obtain an indication of +199.9 on TI. If dc voltage standard or ac/dc voltmeter does not indicate between 0.1993 and 0.2005 V, perform **b**(1) and (2) below.

(3) Reverse polarity of applied voltage and repeat (2) above. If not within tolerance, perform **b**(1) and (3) below.

(4) Repeat (1) above and press 2 range pushbutton.

TB 9-6625-1314-35

(5) Adjust output of dc voltage standard or electrical test set to obtain an indication of +1.999 on TI. If dc voltage standard or ac/dc voltmeter does not indicate between 1.995 and 2.003 V, perform **b**(4) and (5) below.

(6) Adjust autotransformer (A5) from 105 to 125 V while repeating (5) above.

(7) Adjust autotransformer to 115 V.

(8) Press TI range pushbuttons as listed in table 13 and adjust dc voltage standard or electrical test set for corresponding indications. Dc voltage standard or ac/dc voltmeter indications will be within limits s fled.

Table 13. Dc Volts Range and Tracking

Test instrument		Dc voltage standard or ac/dc voltmeter indications (V)	
Range pushbutton	Indication	Min	Max
20	19.99	19.950	20.030
20	18.88	18.841	18.919
20	17.77	17.732	17.808
20	16.66	16.623	16.697
20	15.55	15.514	15.586
20	14.44	14.405	14.474
20	13.33	13.296	13.363
20	12.22	12.187	12.252
20	11.11	11.078	11.141
200	199.9	199.5	200.3
2000	999	994	1004

b. Adjustments

(1) Adjust dc voltage standard on electrical test set for an output of 0.19990 V.

(2) Adjust FS (+.2 VDC) (fig. 6) to obtain an indication of +199.9 on TI.

(3) Adjust NEG FS (-.2 VDC) (fig. 6) to obtain an indication of ±199.9 on TI.

(4) Adjust dc voltage standard on electrical test set for an output of 1.9990 V.

(5) Adjust 2 FS (2 VDC) (fig. 6) to obtain an indication of 1.9990 on TI.

27. Dc Current (Level A)

a. Performance check

(1) Connect equipment as shown in figure 7.

(2) Position plugs of dc current shunt (A6) for 0.001 AMP.

- (3) Press TI mA function pushbutton and .2 range pushbutton.
- (4) Adjust dc voltage standard (A7) and decade resistor (A9) to obtain a 199.9 indication on TI. Ac/dc voltmeter (A3) will indicate between 19.91 and 20.07 mV.

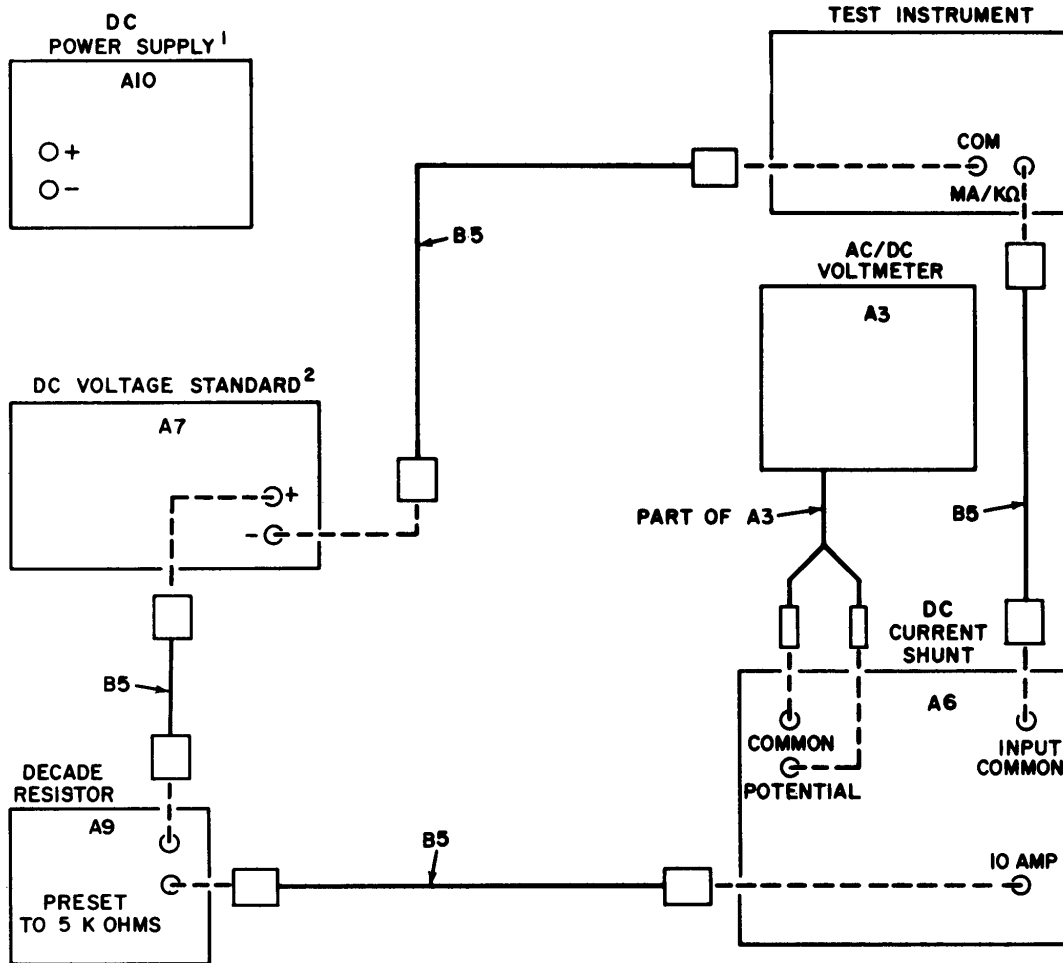

¹ FOR USE ABOVE 20MA

² FOR USE AT 20MA AND BELOW

Figure 7. Dc current - equipment setup.

- (5) Repeat technique of (2) through (4) above, using settings and indications listed in table 14. Ac/dc voltmeter will indicate within limits specified.

Table 14. Dc Current

Current shunt range plus AMPERES position	Test instrument		Ac/dc voltmeter indication (mV dc)	
	Range pushbutton	Indication (mA)	Min	Max
0.01	2	1.999	19.910	20.070
0.1	20	19.99	19.910	20.070
1	200	199.9	19.910	20.070
10	2000	1999	19.830	20.150

b. Adjustments. No adjustments can be made.,

28. Dc Current (AN/GSM-256, AN/GSM-259, and AN/TSM-55)

a. Performance check

- (1) Connect equipment as shown in figure 3, connection A.
- (2) Press TI MA function and .2 range pushbuttons.

CAUTION

All decade positions of decade resistance standard (A8) must be set exactly as specified in (3) below and table 15 to assure maximum current limits of the decades are not exceeded.

Table 15. Dc Current Accuracy (AN/GSM-256, AN/GSM-259, and AN/TSM-55)

Decade resistance standard ohms settings	Test instrument		Ac/dc voltmeter indications (V)	
	RANGE pushbutton	Indication (mA)	Min	Max
002000.00	2	1.999	3.9820	4.0140
000200.00	20	19.99	3.9820	4.0140
000010.00	200	100.0	0.9960	1.0040

- (3) Set decade resistance standard to 020000.00.
- (4) Adjust electrical test set (A11) to obtain an indication of 199.9 on TI. Ac/dc voltmeter (A3) will indicate between 3.9820 and 4.0140 V dc.
- (5) Set electrical test set to 0 (zero) V and repeat technique of (3) and (4) above, using settings and indications listed in table 15.
- (6) Disconnect equipment setup shown in figure 3.
- (7) Connect electrical test set to TI using two leads (B4).

(8) Adjust electrical test set to obtain an indication of 199.9 on TI. Electrical test set will indicate between 199.10 and 200.70 mA.

(9) Press TI 2000 range pushbutton.

(10) Adjust electrical test set to obtain an indication of 1999 on TI. Electrical test set will indicate between 19830 and 20150 mA.

b. Adjustments. No adjustments can be made.

29. Ac Volts (Level A and AN/GSM-259)

a. Performance Check

(1) Connect ac voltage calibrator (A2) to TI VOLTS and COM terminals using cable (B2).

(2) Press TI ac function and 2 range pushbuttons.

(3) Adjust ac voltage calibrator frequency to 100 Hz and voltage to obtain an indication of 1.999 on TI. If ac voltage calibration does not indicate between 1.9790 and 2.0190 V ac, perform **b**(1) and (2) below.

(4) Repeat technique of (2) and (3) above using settings and indications listed in table 16. Ac voltage calibrator will indicate within limits specified.

Table 16. Ac Volts (Level A and AN/GSM-259)

Test instrument		Ac voltage calibration indications (V ac)		
RANGE pushbutton	Indication	Frequency	Min	Max
2	1.999	50 Hz	1.9790	2.0190
2	1.999	1 kHz	1.9790	2.0190
2	1.999	10 kHz	1.9790	2.0190
2	1.999	20 kHz	1.9510	2.0470
2	1.999	100 kHz	1.8870	2.1110
.2	199.9	100 Hz	0.1979	0.2019 ¹
.2	199.9	50 Hz	0.1979	0.2019
.2	199.9	1 kHz	0.1979	0.2019
.2	199.9	10 kHz	0.1979	0.2019
.2	199.9	20 kHz	0.1951	0.2047
.2	199.9	100 kHz	0.1887	0.2111
20	19.99	2 kHz	19.790	20.190 ²
20	19.99	50 Hz	19.790	20.190
20	19.99	100 Hz	19.790	20.190
20	19.99	1 kHz	19.790	20.190
20	19.99	10 kHz	19.790	20.190
200	199.9	50 Hz	197.90	201.90
200	199.9	100 Hz	197.90	201.90

TB 9-6625-1314-35

Table 16. Ac Volts (Level A and AN/GSM-259) - Continued

Test instrument		Ac voltage calibration indications (V ac)		
RANGE pushbutton	Indication	Frequency	Min	Max
200	199.9	1 kHz	197.90	201.90
200	199.9	10 kHz	197.90	201.90
2000	700	50 Hz	689.1	710.9
2000	700	100 Hz	689.1	710.9
2000	700	1 kHz	689.1	710.9
2000	700	10 kHz	689.1	710.9

¹If not within tolerance, perform b(3) and (4) below.

²If not within tolerance, perform b(5) and (6) below.

b. Adjustments

- (1) Adjust ac voltage calibrator for 1.9990 V.
- (2) Adjust 2 VAC (fig. 6) to obtain an indication of 1.999 on TI (R).
- (3) Adjust ac voltage calibrator for 0.1999 V.
- (4) Adjust .2 VAC (fig. 6) to obtain an indication of 199.9 on TI (R).
- (5) Adjust ac voltage calibrator for 19.990.
- (6) Adjust 20 VAC (fig. 6) to obtain an indication of 19.99 on TI (R).

30. Ac Volts (AN/GSM-256 and AN/TSM-55)

a. Performance Check

- (1) Connect signal source (A12) and ac/dc voltmeter (A3) in parallel to TI VOLTS and COM terminals using leads (B4 and B6).
- (2) Press TI ac function and 2 range pushbutton.
- (3) Adjust signal source frequency to 100 Hz and voltage to obtain an indication of 1.999 on TI. If ac/dc voltmeter does not indicate between 1.9790 and 2.0190 V ac, perform **b**(1) and (2) below.
- (4) Repeat technique of (3) above at frequencies of 50 Hz, 1 kHz, and 10 kHz. Ac/dc voltmeter will indicate between 1.9790 and 2.0190 V.
- (5) Adjust signal source frequency to 20 kHz and voltage to obtain an indication of 1.999 on TI. Ac/dc voltmeter will indicate between 1.9510 and 2.0470 V.

(6) Adjust signal source frequency to 100 kHz and voltage to obtain an indication of 1.999 on TI. Ac/dc voltmeter will indicate between 1.8870 and 2.1110 V.

(7) Press TI .2 range pushbutton.

(8) Adjust signal source frequency to 100 Hz and voltage to obtain an indication of 199.9 on TI. If ac/dc voltmeter does not indicate between 0.1979 and 0.2019 V, perform **b**(3) and (4).

(9) Repeat technique of (8) above at frequencies of 50 Hz, 1 kHz, and 10 kHz. Ac/dc voltmeter will indicate between 0.1979 and 0.2019 V.

(10) Adjust signal source frequency to 20 kHz and voltage to obtain an indication of 199.9 on TI. Ac/dc voltmeter will indicate between 0.1951 and 0.2047 V.

(11) Adjust signal source frequency to 100 kHz and voltage to obtain an indication of 199.9 on TI. Ac/dc voltmeter will indicate between 0.1887 and 0.2111 V.

(12) Press TI 20 range pushbutton.

(13) Disconnect signal source from TI and connect signal to ac power supply (A4), using lead supplied with power supply. Connect ac power supply for AN/GSM-256 or test oscillator (A13) for AN/TSM-55 to TI VOLTS and COM terminals using lead (B4). Leave ac/dc voltmeter connected in parallel.

(14) Adjust ac power supply or test oscillator frequency to 2 kHz and voltage to obtain an indication of 19.99 on TI. If ac/dc voltmeter does not indicate between 19.790 and 20.190 V, perform **b**(5) and (6) below.

(15) Adjust ac power supply or test oscillator frequency to 50 Hz and voltage to obtain an indication of 19.99 on TI. Ac/dc voltmeter will indicate between 19.790 and 20.190 V.

(16) Repeat technique of (15) above at frequencies of 100 Hz, 1 kHz, and 10 kHz.

(17) Disconnect equipment setup and connect electrical test set (A11) to TI VOLTS and COM terminals using cable (B2).

(18) Press TI 200 range pushbutton.

(19) Adjust electrical test set frequency to 60 Hz and voltage to obtain an indication of 199.9 on TI. Electrical test set will indicate between 197.90 and 201.90 V.

(20) Repeat (19) above with electrical test set frequency set to 400 Hz.

(21) Press TI 2000 range pushbutton.

(22) Adjust electrical test set frequency to 60 Hz and voltage to obtain an indication of 700 V on TI. Electrical test set will indicate between 689.1 and 710.9 V.

TB 9-6625-1314-35

(23) Repeat (22) above with electrical test set frequency set to 400 Hz.

b. Adjustments

- (1) Adjust signal source to obtain an indication of 1.9990 V on ac/dc voltmeter.
- (2) Adjust 2 VAC (fig. 6) to obtain an indication of 1.999 on TI (R).
- (3) Adjust signal source to obtain an indication of 0.19990 V on ac/dc voltmeter.
- (4) Adjust .2 VAC (fig. 6) to obtain an indication of 199.9 on TI (R).
- (5) Adjust ac power supply on test equipment to obtain an indication of 19.990 V on ac/dc voltmeter.
- (6) Adjust 20 VAC (fig. 6) to obtain an indication of 19.99 on TI (R).

31. Ac Current (Level A)

a. Performance check

(1) Connect equipment as shown in figure 8.

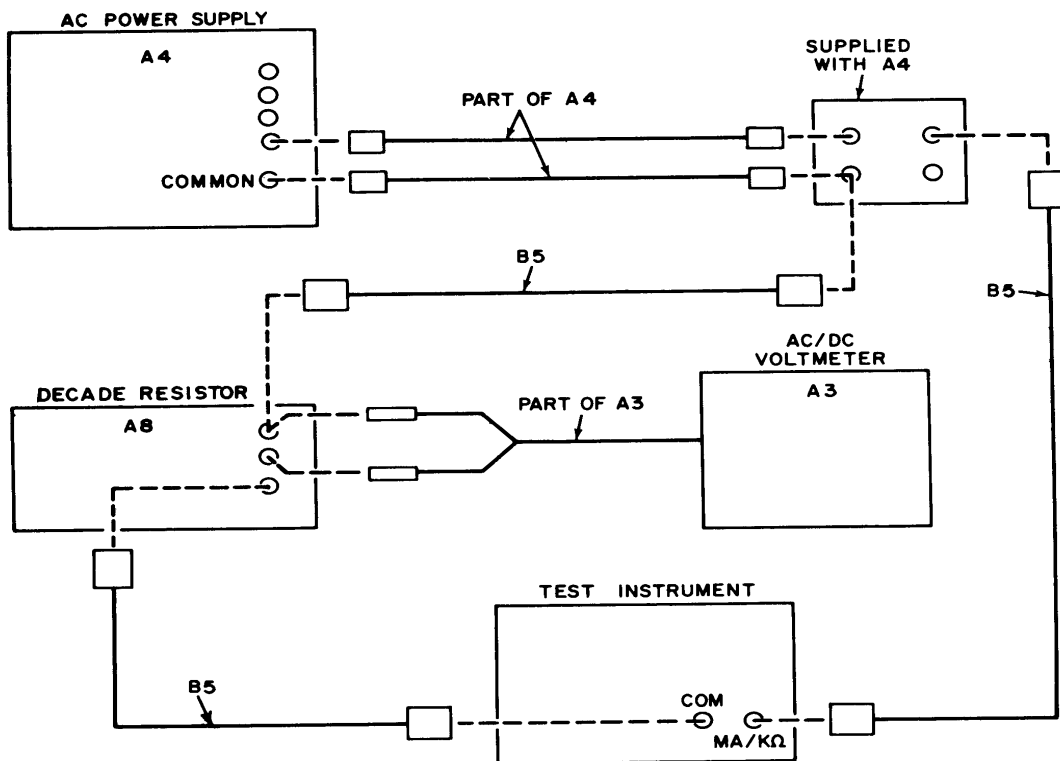

Figure 8. Low ac current - equipment setup.

- (2) Press TI .2 range pushbutton and simultaneously press AC and MA function pushbuttons.
- (3) Adjust decade resistance standard (A8) to 5000 Ω .
- (4) Adjust frequency of power supply (A4) to 1000 Hz and voltage to obtain an indication of 199.9 on TI. Ac/dc voltmeter (A3) will indicate between 0.9895 and 1.0095 V ac.
- (5) Repeat (4) above for frequency of 50 Hz, 5 kHz, and 10 kHz.
- (6) Press TI 2 range pushbutton and adjust decade resistance standard to 500 Ω .
- (7) Adjust frequency of ac power supply to 1000 Hz and output to an indication of 1.999 on TI. Ac/dc voltmeter will indicate between 0.9895 and 1.0095 V ac.
- (8) Repeat (1) above for frequencies of 50 Hz, 5 MHz, and 10 kHz.
- (9) Connect equipment as shown in figure 9.

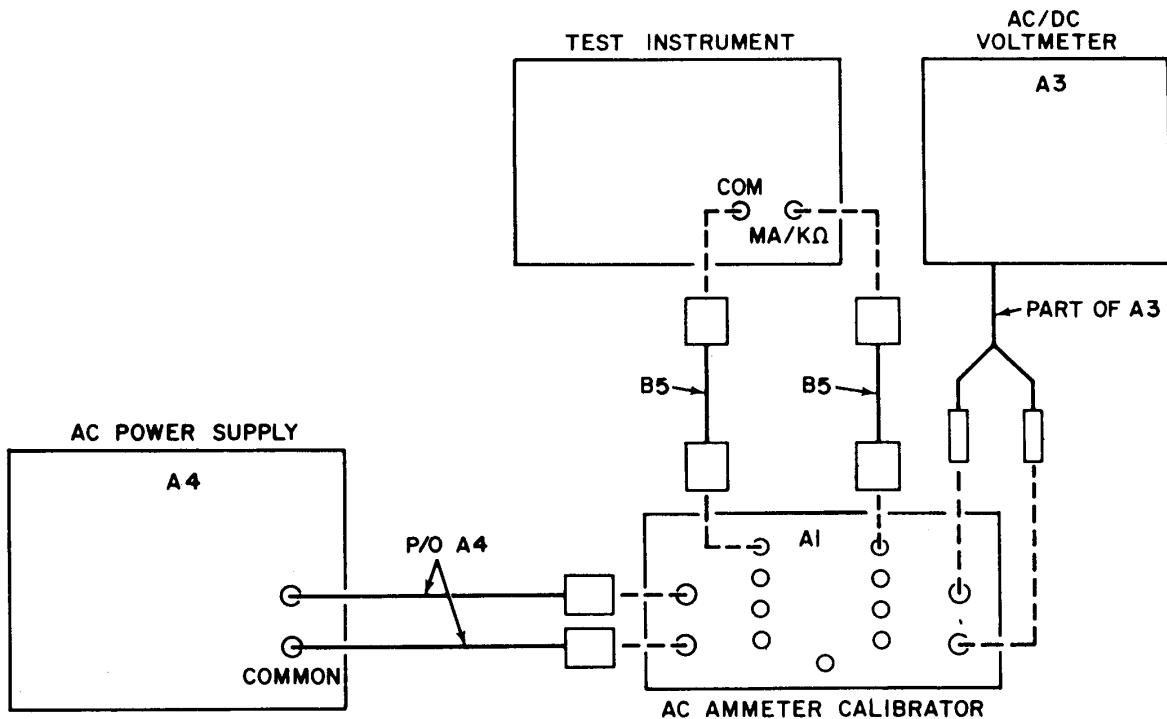

Figure 9. High ac current equipment setup.

- (10) Adjust ac ammeter calibrator (A1) for a 19.99 mA measurement and press TI 20 range pushbutton.

TB 9-6625-1314-35

(11) Adjust power supply frequency for 1000 Hz and voltage to obtain an indication of 19.99 on TI. Ac/dc voltmeter will indicate between 0.99 and 1.01 V ac.

(12) Repeat (11) above at frequencies of 50 Hz, 5 kHz and 10 kHz.

(13) Press TI 200 range pushbutton and make connections to ac ammeter calibrator for 199.9 mA measurement.

(14) Adjust frequency of ac power supply to 1000 Hz and output to an indication of 199.9 on TI. Ac/dc voltmeter will indicate between 0.99 and 1.01 V ac.

(15) Repeat (14) above for frequencies at 50, 5 and 10 kHz.

(16) Press TI 2000 range pushbutton and make connections to ac ammeter calibrator for a 1.999 amp measurement.

(17) Adjust frequency of ac power supply to 1000 Hz and output to an indication of 1.999 on TI. Ac/dc voltmeter will indicate between 0.99 and 1.01 V ac.

(18) Repeat (17) above for frequencies of 50, 5 and 10 kHz.

b. Adjustments. No adjustments can be made.

32. Ac Current (AN/GSM-256)

a. Performance Check

(1) Press TI .2 range pushbutton and simultaneously press AC and MA function pushbuttons.

(2) Connect equipment as shown in figure 3, connection B.

CAUTION

All decade positions of decade resistance standard (A8) must be set exactly as specified in (3) below and table 17 to assure maximum current limits of the decades are not exceeded.

Table 17. Ac Current Accuracy (AN/GSM-256)

Decade resistance standard ohms settings	Test instrument		Ac/dc voltmeter indications (V ac)	
	RANGE pushbutton	Indication (mA)	Min	Max
0020000.00	2	1.999	3.9580	4.0380
000200.00	20	19.99	3.9580	4.0380
000010.00	200	100.00	0.9900	1.0100

- (3) Set decade resistance standard to 020000.0
- (4) Adjust ac power supply (A4) frequency to 1 kHz and voltage to obtain an indication of 199.9 on TI. Ac/dc voltmeter will indicate between 3.9580 and 4.0380 V ac.
- (5) Repeat technique of (4) above at frequencies of 50 and 400 Hz. Ac/dc voltmeter will remain between 3.9580 and 4.0380 V ac.
- (6) Repeat technique of (3) through (5) above using settings and indications listed in table 19. Ac/dc voltmeter will indicate within limits specified.
- (7) Disconnect equipment setup shown in figure 3.
- (8) Connect electrical test set (A11) to TI using two leads (B4).
- (9) Press TI 200 range pushbutton.
- (10) Adjust electrical test set frequency to 60 Hz and voltage to obtain an indication of 199.9 on TI. Electrical test set will indicate between 197.90 and 201.90 mA.
- (11) Repeat technique of (10) above with electrical test set frequency set to 400 Hz. Electrical test set will remain between 197.90 and 201.90 mA.
- (12) Press TI 2000 range pushbutton.
- (13) Adjust electrical test set frequency to 60 Hz and voltage to obtain an indication of 1999 on TI. Electrical test set will indicate between 19790 and 20190 mA.
- (14) Repeat (13) above with electrical test set frequency set to 400 Hz. Electrical test set will remain between 19790 and 20190 mA.

b. Adjustments. No adjustments can be made.

33. Ac Current (AN/GSM-259 and AN/TSM-55)

a. Performance Check

- (1) Press TI .2 range pushbutton.
- (2) Connect electrical test set (A11) to TI using two leads (B4).
- (3) Adjust electrical test set frequency for 400 Hz and voltage to obtain an indication of 199.9 on TI. Electrical test set will indicate between 197.90 and 201.90 mA.
- (4) Repeat (3) above with electrical test set frequency set to 60 Hz. Electrical test set will remain between 197.90 and 201.90 mA.

TB 9-6625-1314-35

(5) Repeat technique of (1) through (4) above using settings and indications listed in table 18. Electrical test set will indicate within limits specified.

Table 18. Ac Current (AN/GSM-259 and AN/TSM-55)

Test instrument		Electrical test set indications (mA)	
Range	Indications (mA)	Min	Max
2	1.999	1.9790	2.0190
20	19.99	19.790	20.190
200	199.9	197.90	201.90
2000	1999	1979.0	2019.0

b. Adjustments. No adjustments can be made.

34. Resistance

a. Performance Check

(1) Press kΩ pushbutton and .2 range pushbutton.

(2) Connect decade resistance standard (A8) between TI COM and MA/kΩ terminals, using two leads (B4).

(3) Adjust decade resistance standard to obtain an indication of 199.9 on TI. If decade resistance standard does not indicate between 198.9 and 200.9 ohms, perform **b** below.

(4) Repeat technique of (3) above, using settings and indications listed in table 19. If decade resistance standard does not indicate within limits perform corresponding adjustments listed in table 19.

Table 19. Resistance Accuracy

Test Instrument		Decade resistance standard indication (kΩ)		Adjustment (fig. 6)
RANGE pushbutton	Indication	Min	Max	
2	1.999	1.989	2.009	---
20	19.99	19.89	20.09	20 K OHM ADJ (R)
200	199.9	198.9	200.9	---
2000 ¹	1999	1985	2013	2 M OHM ADJ. (R)

¹Connect two resistance standards (A8) in series.

b. Adjustments

(1) Adjust decade resistance standard to 199.90 ohms.

(2) Adjust .2 kΩ (fig. 6) to obtain an indication of 199.9 on TI (R).

35. Final Procedure. In accordance with TM 38-750, annotate and affix DA Label 80 (US Army Calibrated Instrument). When the TI receives limited or special calibration, annotate and affix DA Label 163 (US Army Limited or Special Calibration). When the TI cannot be adjusted within tolerance, annotate and affix DA Form 2417 (US Army Calibration System Rejected Instrument).

TB 9-6625-1314-35

By Order of the Secretary of the Army:

E. C. MEYER
General, United States Army
Chief of Staff

Official:

J. C. PENNINGTON
Major General, United States Army
The Adjutant General

Distribution:

To be distributed in accordance with DA Form 12-34A (qty rqr block No. 75), requirements for calibration procedures publications.

U.S. GOVERNMENT PRINTING OFFICE: 1979 - 640-042/1418

PIN NO: 043301-000